

These parts are designed for impact protection. A range of sizes is available with many held in stock.

Some styles are subject to minimum order quantities. Alternatively rectangular buffers can be manufactured from rail, in a wide range of sizes.

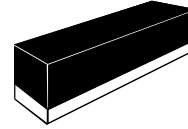

Part No. RECT-RB1099

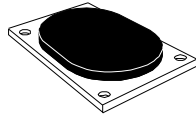
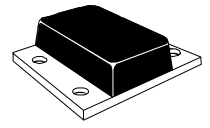
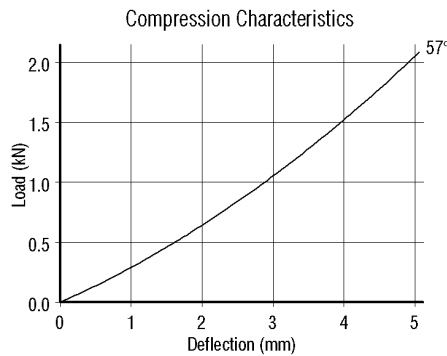
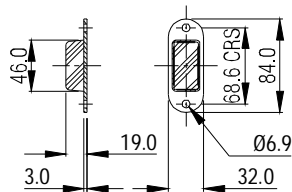

Part No. RECT-RB1105

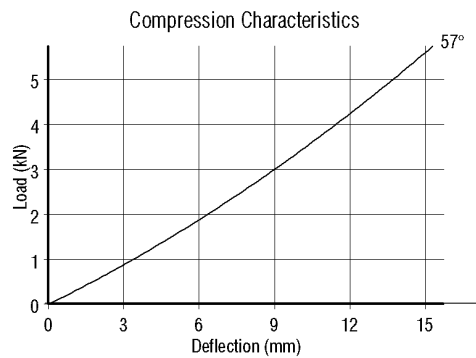
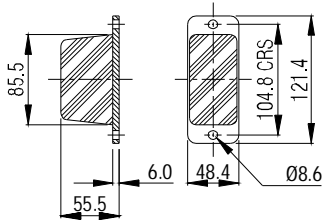

Part No. RECT-RB1107

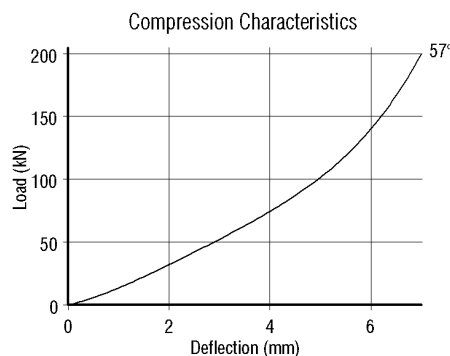
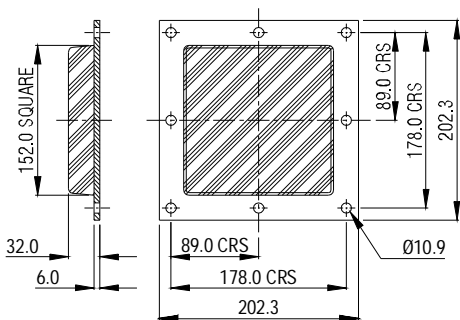

Part No. RECT-RB1211

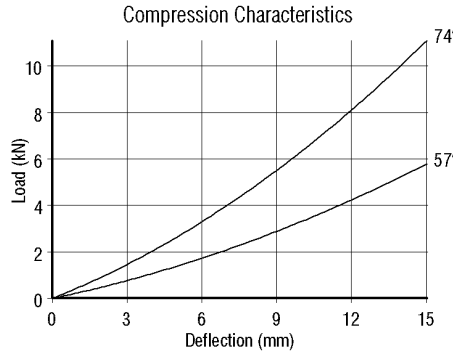
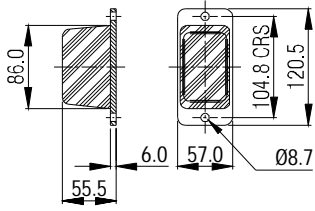

Part No. RECT-RB1212

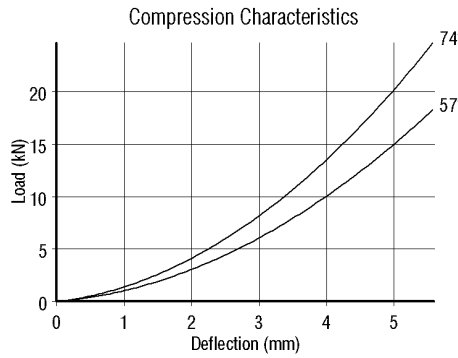
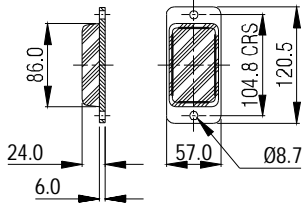

Part No. RECT-RB1221

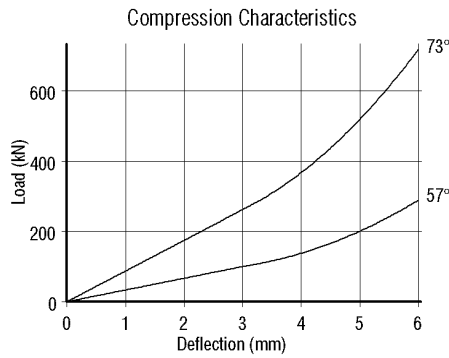
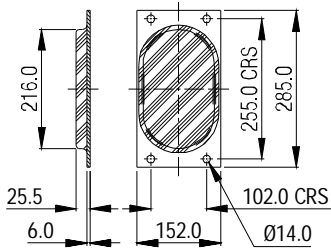

Part No. RECT-RB1238

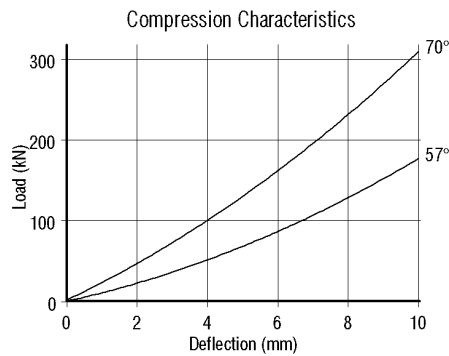
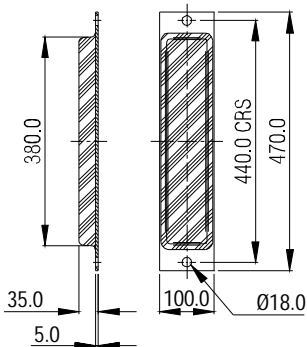

Rectangular Buffers Cut From Rail

It is possible to manufacture Rectangular Buffers from Rail as illustrated. The Rail can be supplied as manufactured in 2 metre lengths, or can be cut and drilled to meet the customer's individual requirement. This process has the added advantage that no tooling is normally required.

