

A range of sizes and styles can be manufactured, incorporating mounting holes and/or stud fastenings, and one or more interleaves. Minimum order quantities may apply unless parts are available from stock.

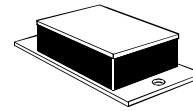

Part No. MTG-MTG1081

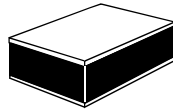
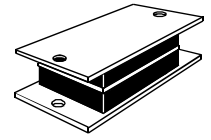
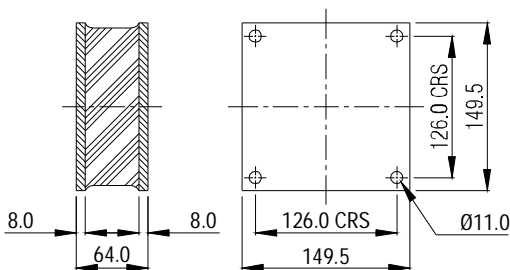

Part No. MTG-MTG1085

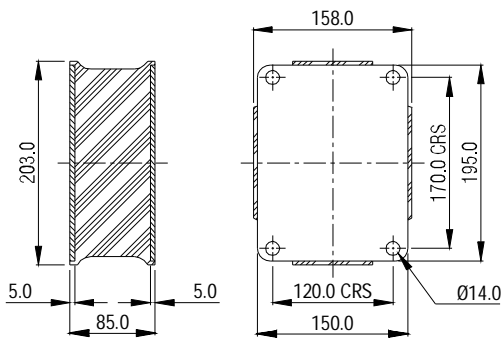

Mountings Cut From Rail

It is possible to manufacture Mountings from Rail as illustrated. The Rail can be supplied as manufactured in 2 metre lengths, or can be cut and drilled to meet the customer's individual requirement. This process has the added advantage that no tooling is normally required.

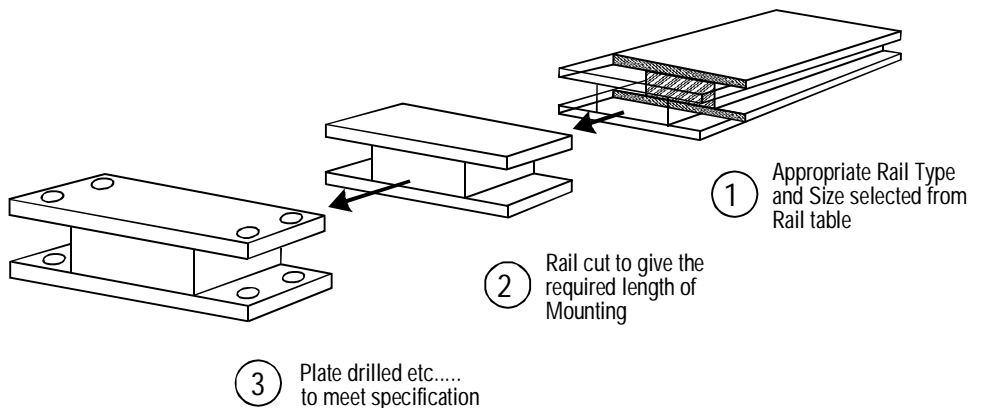

Part No. MTG-MTG1109

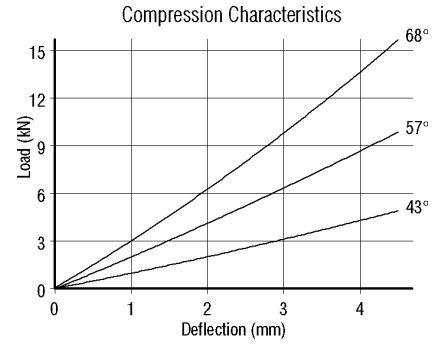
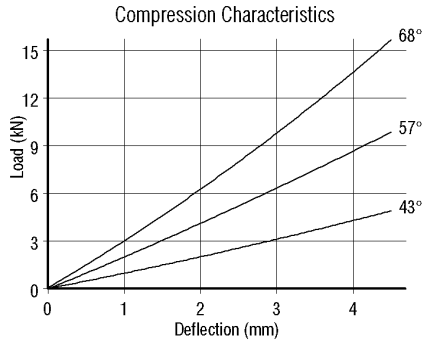
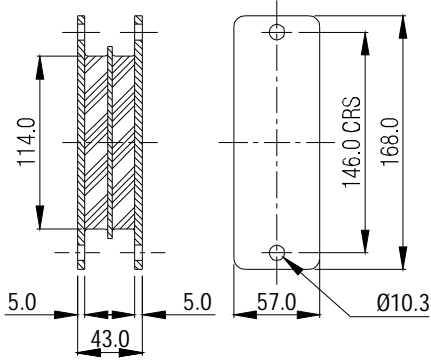

Part No. MTG-MTG1136

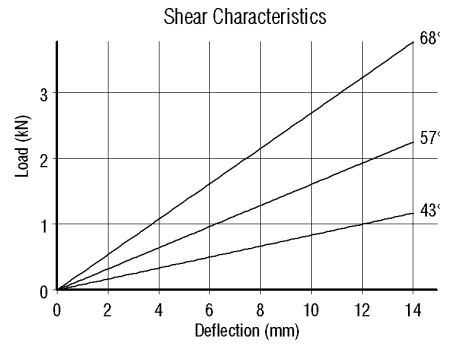
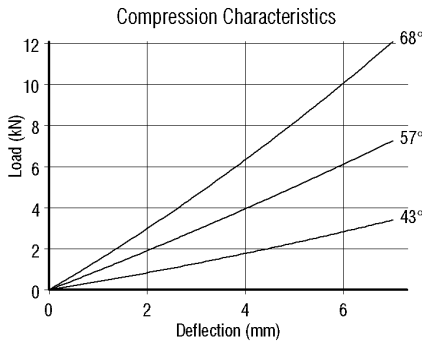
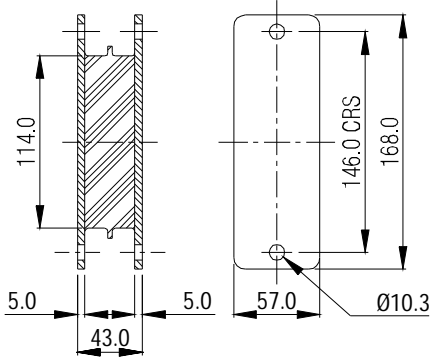

Part No. MTG-MTG1169

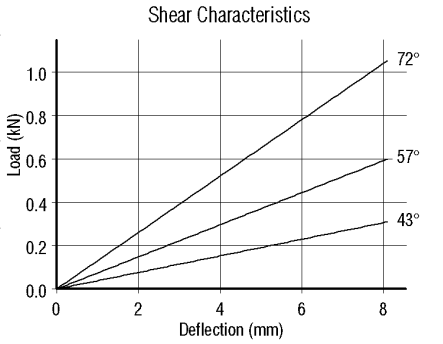
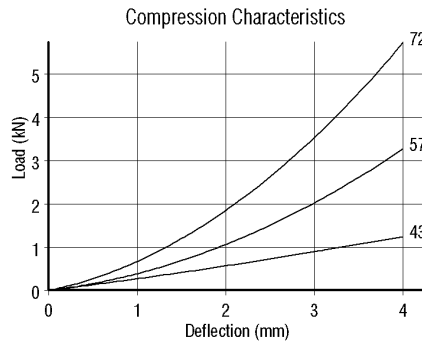
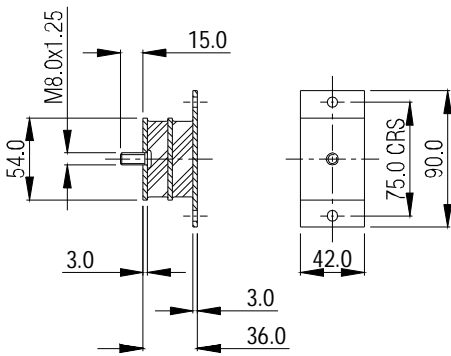

Part No. MTG-MTG1177

