

A range of sizes is available with many held in stock. Due to their design, the parts can be loaded in any of the three planes - vertical shear, horizontal shear and horizontal compression, and allow relatively high deflections to be achieved.

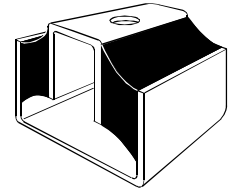

Part No. U-MTG1470

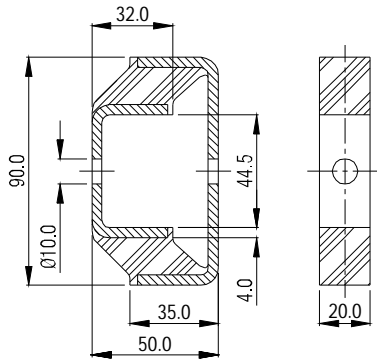

Part No. U-MTG1471

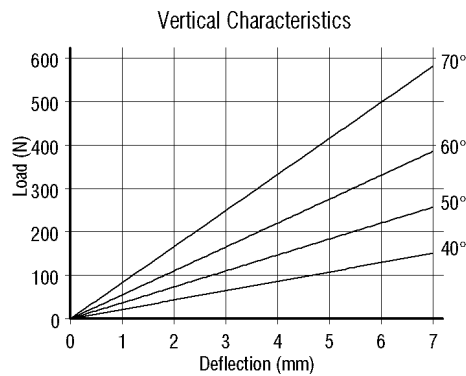
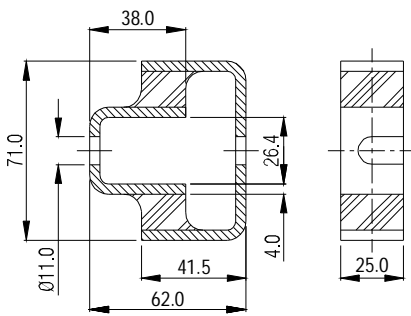

Part No. U-MTG1506

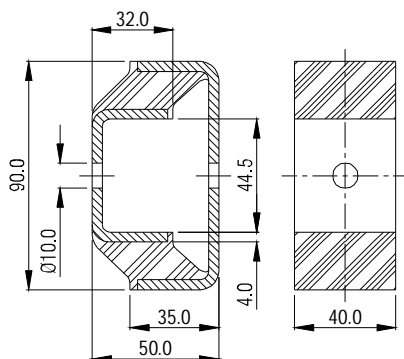

Part No. U-MTG1246

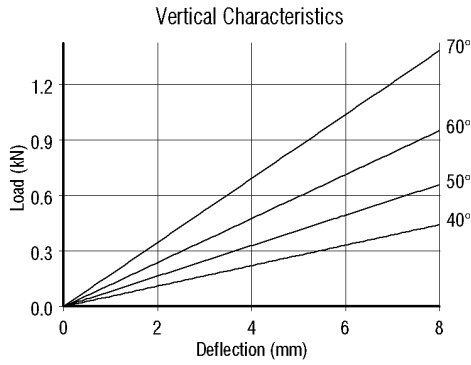
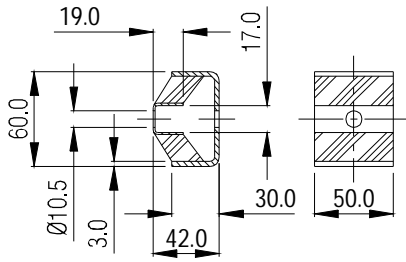

Part No. U-MTG1472

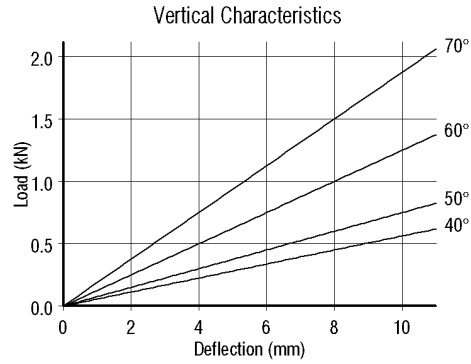
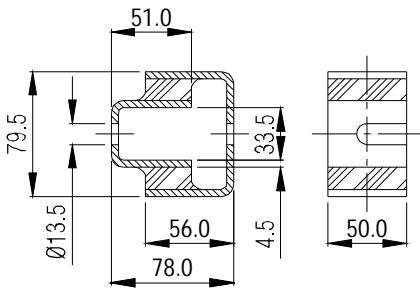

Part No. U-MTG1473

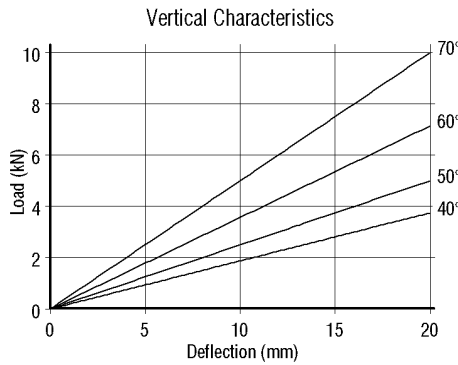
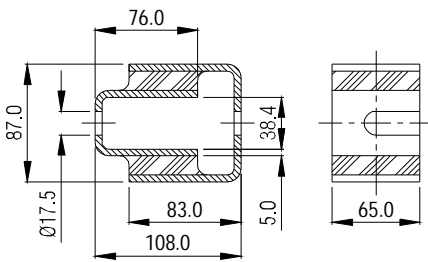

Part No. U-MTG1474

