

Triflex Mountings

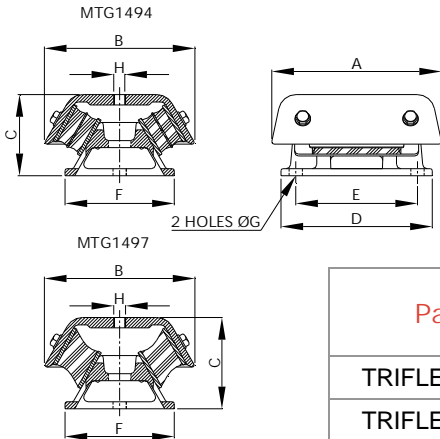

Two main types of Triflex Mountings are available Type 1 and Type 2. These are available in a variety of sizes with many held in stock. The design of the Triflex mountings provides different degrees of stiffness in the three main axes. Special Triflex mounts are also available with integrated height adjustment and tie-down features.

Triflex Mountings (Type 1)



GMT Triflex Type 1 mountings have been developed for heavy duty machinery, the protection of precision machinery and electronic installations from vibration. The mounts provide relatively high deflections and the design is such that there are different degrees of stiffness in the three main axes.

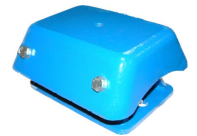

Part No.	A (mm)	B (mm)	C (mm)	D (mm)	E (mm)	F (mm)	G (mm)	H
TRIFLEX-MTG1494	230	204	110.5	205	165	148	18	M16
TRIFLEX-MTG1497	230	204	123.5	205	165	148	18	M16

Compression Characteristics

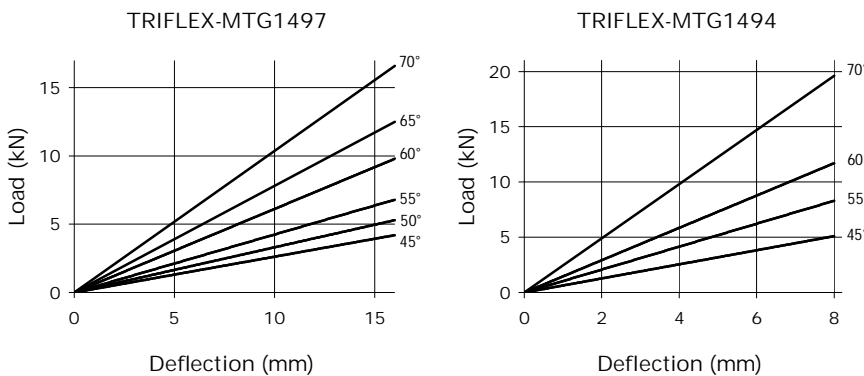

Note: There is a possible deviation of $\pm 20\%$ in the above load/deflection graphs due to production and hardness tolerances

Adjustable Studs

GMT Adjustable studs are available in 3 main sizes to be used with the Triflex mounting range where height adjustment is required.

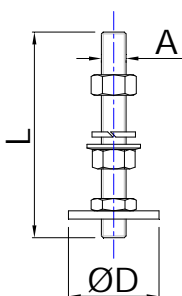

Part No.	A	L (mm)	ØD (mm)
STUD-M2196	M12 x 1.75	100	44.0
STUD-M2197	M16 x 2.0	110	56.0
STUD-M2198	M20 x 2.5	150	72.0



Triflex Mountings (Type 2)

GMT Triflex Type 2 mountings have been developed for the insulation of static and mobile machines and engines in particularly for Marine applications. The mounts provide different degrees of stiffness in the three main axes and also have integrated rebound control.

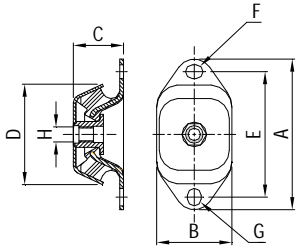

Part No.	A (mm)	B (mm)	C (mm)	D (mm)	E (mm)	F (mm)	G (mm)	H
TRIFLEX-MTG1086	120	60	40	80	100	11x14	11x14	M12
TRIFLEX-MTG1087	184	75	50	103.5	140	20x13	20x13	M16
TRIFLEX-MTG1088	230	112	70	133.0	182	26x18	26x18	M20

Compression Characteristics

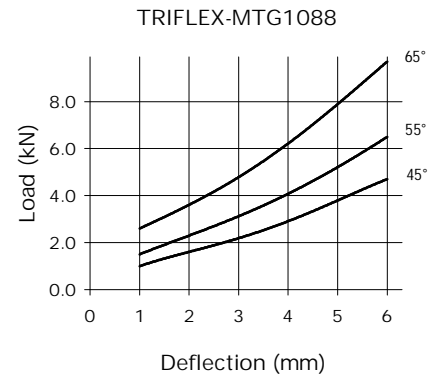
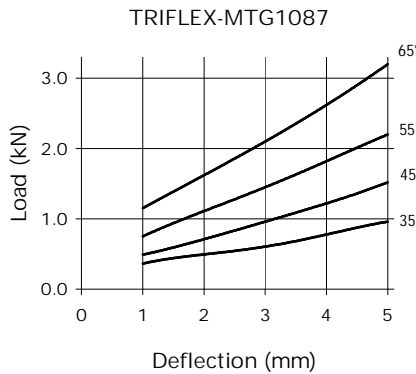
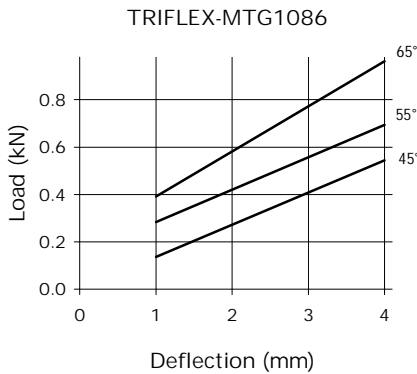

Note: There is a possible deviation of ±20% in the above load/deflection graphs due to production

Special Triflex Mounting (MTG2218)

GMT Special Triflex Mounts have been developed for the insulation of static and mobile machines and engines in particularly for Marine applications. The mounts provide different degrees of stiffness in the three main axes and also have integrated rebound control.

These parts can be manufactured and supplied with or without the adjustable top bolt and with or without the four tie down bolts.

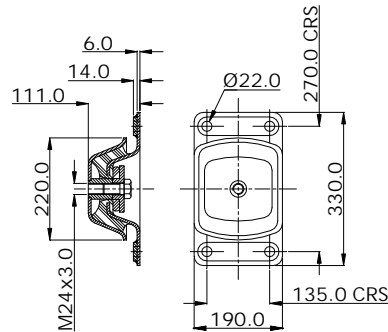

Stiffness Characteristics

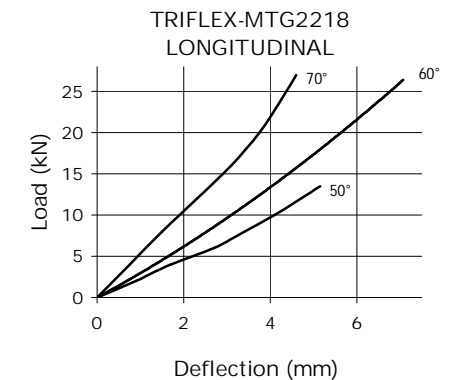
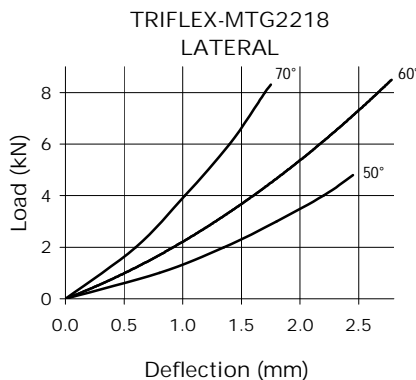
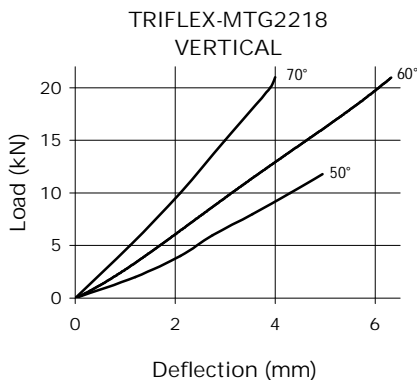

Note: There is a possible deviation of ±20% in the above load/deflection graphs due to production and hardness tolerances

TRIFLEX-MTG2019

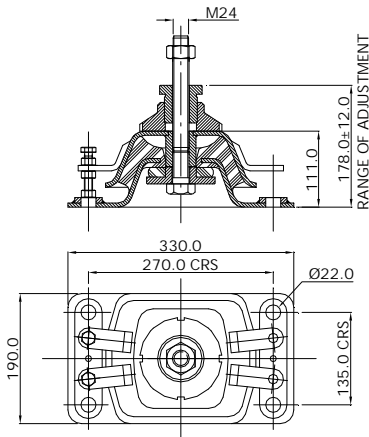

Compression Characteristics

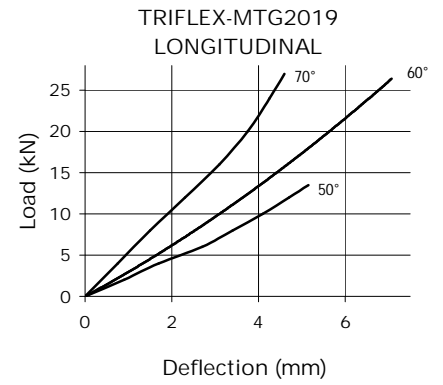
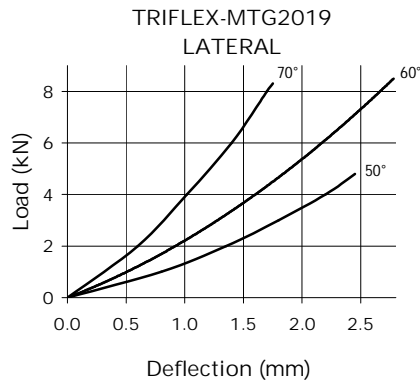
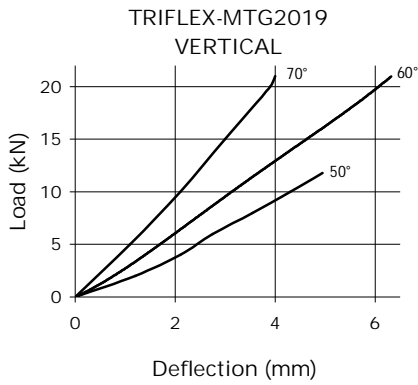

Note: There is a possible deviation of ±20% in the above load/deflection graphs due to production and hardness tolerances