

Rectangular Buffers

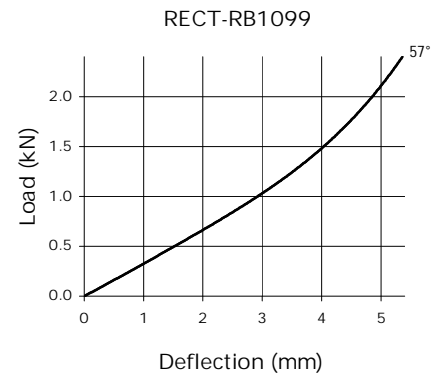

These parts are designed for impact protection. A range of sizes is available with many held in stock. Some styles are subject to minimum order quantities. Alternatively rectangular buffers can be manufactured from rail in a wide range of sizes.

RECT-RB1099

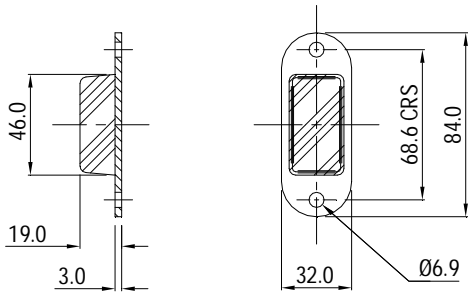

RECT-RB1105

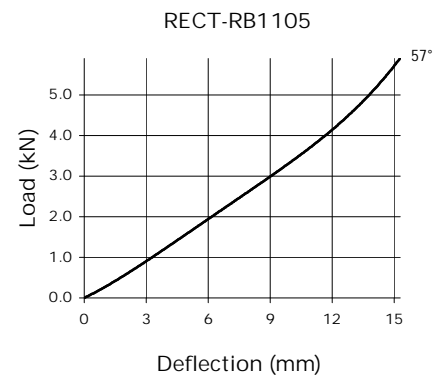
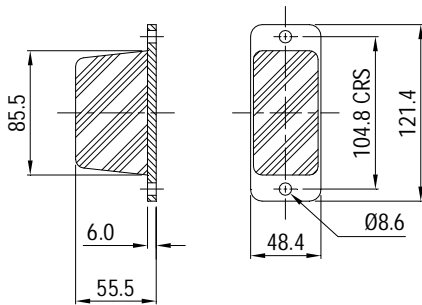

RECT-RB1107

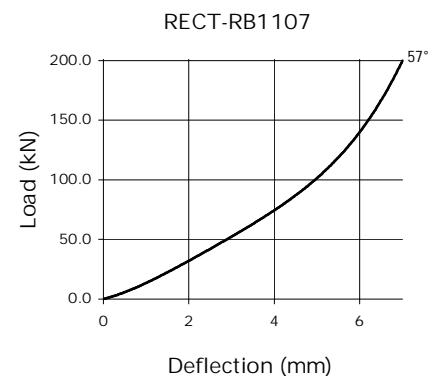
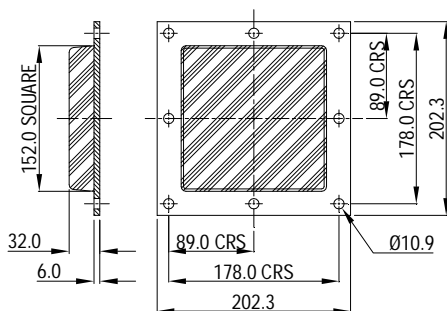

Note: There is a possible deviation of $\pm 20\%$ in the above load/deflection graphs due to production and hardness tolerances

RECT-RB1211

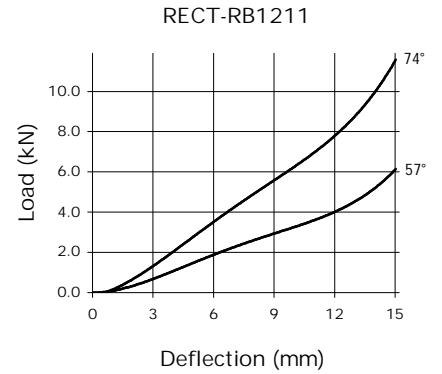
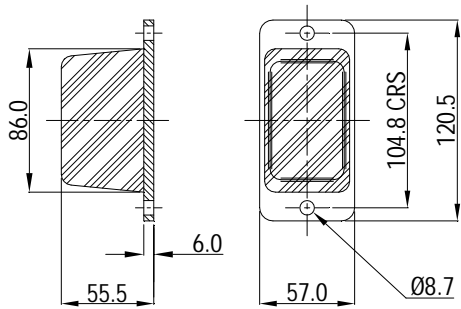

RECT-RB1212

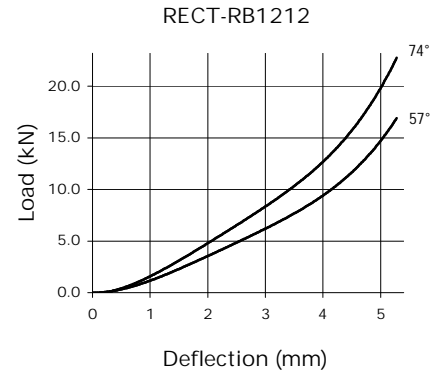
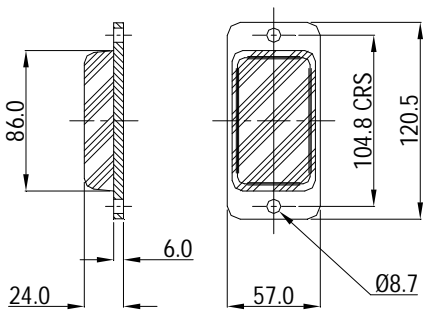

RECT-RB1221

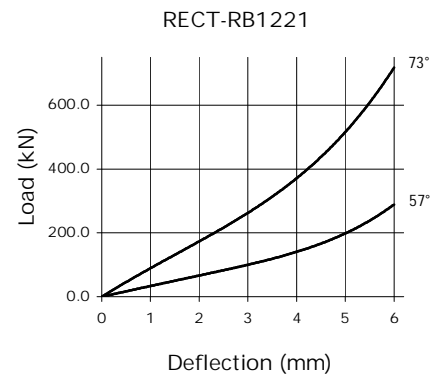
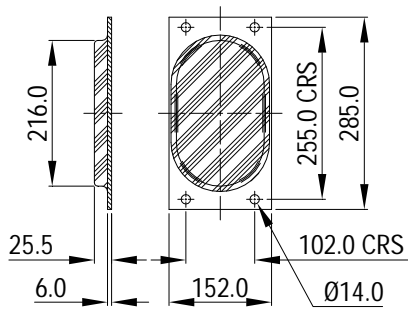

RECT-RB1238

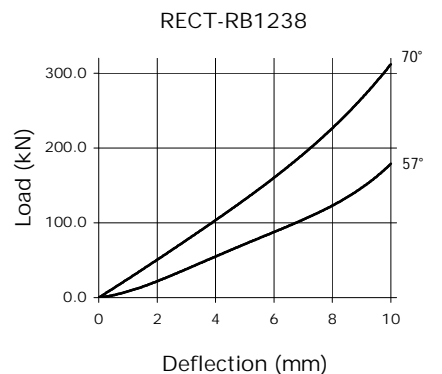
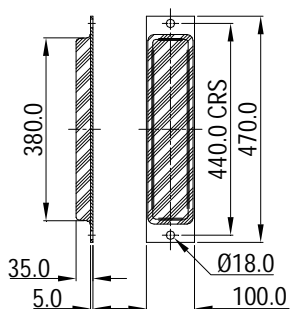

Note: There is a possible deviation of $\pm 20\%$ in the above load/deflection graphs due to production and hardness tolerances

Rectangular Buffers Cut From Rail

It is possible to manufacture Rectangular Buffers from Rail as illustrated. The rail can be supplied as manufactured in 2 metre lengths, or can be cut and drilled to meet the customer's individual requirement. This process has the added advantage that no tooling is normally required

