

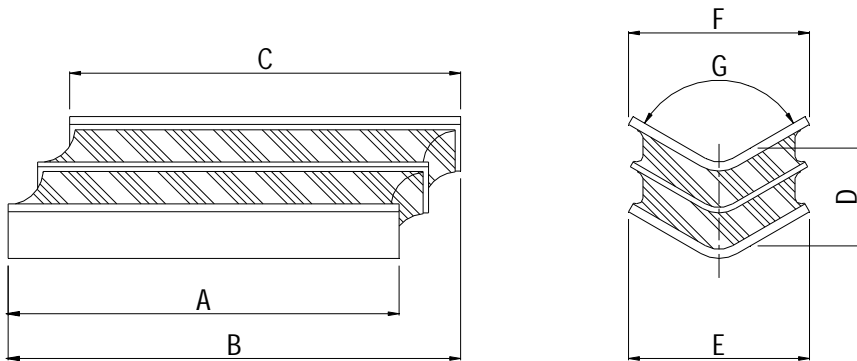

Chevron Springs

A range of sizes and styles is available from existing tooling. Some parts may be available from stock although they are normally manufactured to meet customers' requirements

CHEVRON SPRINGS



Part No.	A (mm)	B (mm)	C (mm)	D (mm)	E (mm)	F (mm)	G °	Location Bar/Pin	No. of Interleaves
AS1854	152	197	177	60	186.5	146	120	Pin	1
AS1510	186	205	186	54	100	100	120	—	1
AS1589	139.5	209	177.5	90	193	147.5	120	Bar	2
AS1888	139.5	209	177.5	90	193	147.5	120	—	2
AS1519	152	214	182	77	80	80	120	—	2
AS1511	216	250	216	54	100	100	120	—	1
AS1512	200	263	213	94.5	120	120	120	—	2
AS1346	194	286	248	115	176	137	120	Pin	3
AS1365	248	294	248	67	125	125	120	—	1
AS1514	246	307	246	93	145	145	120	—	2
AS1513	248	329	248	94.5	125	125	120	—	2
AS1965	216	340	308	133	252	167	106	Bar	2
AS1517	203	341	292	179	270	184	120	Bar	4
AS1518	235	363	267	193	260	160	120	—	5
AS1516	258	365	303	150	230	192	120	—	4
AS2251	300	377	344	111.4	235	170	120	—	2